



# PRESS RULES

## SUMMARY

<b>GENERAL CONDITIONS</b>	<b>p 2</b>
DIFFERENT ACCREDITATION	
ACCREDITATIONS FOR JOURNALISTS / PHOTOGRAPHERS	
ACCREDITATIONS FOR PRESS OFFICERS	
PRESS ROOMS	
AVAILABLE INFORMATION	
TRANSMISSIONS	
<b>INSURANCE</b>	<b>p 5</b>
THIRD PARTY LIABILITY	
ASSISTANCE / MEDICAL REPATRIATION	
MEDICAL EXPENSES	
<b>TARIFFS</b>	<b>p 9</b>
PRESS PLANE	
PRESS CAR	
PRESS OFFICERS	
<b>PRESS PLANE PACK</b>	<b>p 11</b>
ADMINISTRATIVE OBLIGATIONS	
HELICOPTERS	
COMPETITOR ASSISTANCE	
TRANSPORT	
LODGING AND CATERING	
LUGGAGE	
<b>PRESS OFFICER PACK</b>	<b>p 13</b>
ADMINISTRATIVE OBLIGATIONS	
COMPETITOR ASSISTANCE	
TRANSPORT	
LODGING AND CATERING	
LUGGAGE	
<b>PRESS CAR PACK</b>	<b>p 14</b>
ADMINISTRATIVE OBLIGATIONS	
ITINERARY	
CATERING	
DEPOSIT	
COMPETITORS ASSISTANCE	
ELIGIBLE VEHICLES	
NON RESPECT OF REGULATIONS	
TRAFFIC	
TECHNICAL REGULATIONS FOR PRESS VEHICLES	
SAFETY EQUIPMENT	
ASSISTANCE COURSE PRESS CARS SPECIFICATION	
ROLL BARS	
IDENTIFICATION MARKINGS	
SECURITY	
FUEL	
TRACK CLOSURE	
<b>CONTACTS</b>	<b>p 20</b>
<b>INDIVIDUAL ATTESTATION</b>	<b>p 21</b>

# GENERAL CONDITIONS

The Euromilhoes Dakar 2008 will be held from the 5<sup>th</sup> to 20<sup>th</sup> of January 2008, going from Lisbon to Dakar. Scrutineering will take place on the 2<sup>nd</sup>, 3<sup>rd</sup> and 4<sup>th</sup> of January 2008 in Lisbon.

## DIFFERENT ACCREDITATION

### 1. Daily accreditation:

- ▶ Scrutineering in Lisbon (2<sup>nd</sup>, 3<sup>rd</sup> and 4<sup>th</sup> of January 2008)
- ▶ First stages in Portugal (5<sup>th</sup> & 6<sup>th</sup> of January)
- ▶ Arrival in Dakar (20<sup>th</sup> of January)

### 2. Permanent press accreditation :

- ▶ By plane, chartered by the organization, from Lisbon to Dakar, from the 2<sup>nd</sup> to the 20<sup>th</sup> of January 2008 – "Press Plane Pack". For daily national newspaper journalist, radio reporter, national press agency journalist or photographer only.
- ▶ By press cars (not provided by the organisation) "race course" from the 2<sup>nd</sup> to the 20<sup>th</sup> of January 2008 – "Press Car Pack".
- ▶ By press cars (not provided by the organisation) "assistance course" from the 2<sup>nd</sup> to the 20<sup>th</sup> of January 2008 – "Press Car Pack".

### 3. Permanent press officer accreditation:

- ▶ By plane, chartered by the organization, from Portimao to Dakar, from the 2<sup>nd</sup> to the 20<sup>th</sup> of January 2008 – "Press Officer Pack".

The permanent accreditations are valid for the whole rally. No change of name will be possible during the event.

**Other than for local press, no accreditations will be given out for the stages in Africa.**

## JOURNALISTS / PHOTOGRAPHERS ACCREDITATION

Each request for a press accreditation will have to be done by the **chief editor of the media before the 15<sup>th</sup> of October**. Any individual request will systematically be refused. The request will have to be signed by the **chief editor** added to the media stamp.

To be accredited, the journalist needs to have a **professional press card** (national card or AIPS) in a valid period and the request has to come alongside:

- ⇒ a letter coming from a media employing the journalist insisting on the goal of his mission and the planning of the publications about the rally
- ⇒ published press articles signed by the journalist during the last two years, concerning motorsports and rally-raids.
- ⇒ A sample of the media

**After receiving the files, A.S.O. will study the requests and will accept or not the accreditation.**

## PRESS OFFICER ACCREDITATION

When mentioning "press officer", ASO means any person that is a press officer on a yearly basis and that officially represents a constructor, an official team or a sponsor having at least three (3) vehicles competing under the same team name. This person can not be assimilated to a journalist, a team manager, a mechanic, etc.



They will of course not be allowed to intervene on the race vehicles. In the case of an infringement, the competitor having received help will receive a penalty than can go up to the withdrawal from the rally.

They are not authorised to transport tools or spare parts in the plane.

A same constructor team can have the possibility of having **a maximum of two press officers**, if places are available. No changes of names are authorised during the event, unless a case of absolut necessity occurs and is noted by ASO.

### **PRESS ROOMS**

Fully equipped press rooms (tables, chairs, lights, electrical plugs, ...) will be available for every stage, in Europe and on the African bivouacs.

They will be available to those having an accreditation delivered by the ASO press service.

⇒ Lisbon – Belem Cultural Center

✓ 2<sup>nd</sup>, 3<sup>rd</sup> and 4<sup>th</sup> of January 2008

⇒ Portimao

✓ 5<sup>th</sup> and 6<sup>th</sup> of January 2008

⇒ Bivouacs in Africa

✓ from the 7<sup>th</sup> to the 20<sup>st</sup> of January 2008 – opening hour in the morning - closing hour at 22h00 (rally time)

⇒ Dakar – Hôtel Méridien

✓ 20<sup>th</sup> of January 2008

### **AVAILABLE INFORMATION**

All the press information will be available and released by the press service in French and English: race news, competitor positions during the specials, standings, press releases, interviews,...

They can be found on boards outside the press room and will also be available on the official website [www.dakar.com](http://www.dakar.com)

All the journalists and press officers will have access to an "INTRANET" site, provided by the organisation: Positions, standings, press releases, interviews, race info,...

To get all this information, it is important to contact TD Com to **configure your computers (only PC) before the start of the event or during scrutineering in Lisbon. An appointment will be held at TD Com during the month of December 2006.** ASO will soon release further information.

Self service computers will be made available to use the Intranet system in the press rooms in Africa. These computers are only available to the media.



## **TRANSMISSIONS**

### ⇒ Lisbon, Portimao and Dakar

A wi-fi system will be available in Portugal. ASO will not be delivering phone lines, faxes, internet or e-mail connections to journalists or press officers, in the press rooms in Europe and Dakar. The journalist who wish to have a line will specifically have to contact the ASO press service.

### ⇒ Bivouacs in Afrique

ASO will settle for the 2008 Dakar, a high quality transmission system offering extensive working facilities. It will be available, every day, as soon as the media center is set up, and will work **until 10.00 p.m.**

To know more on how the system works, the tariffs and how to benefit from it, please see the press service.

### **Example: 2007 tariffs**

- ✓ HF phone rental: 250 €
- ✓ Phone communication: 4 € / min. (given and received calls)
- ✓ Internet connection, sending e-mails and files: 4 € / 100 kbits

### **"Personal pack": estimate on demand to the ASO press service**

- ✓ personal seat in the press rooms,
- ✓ fixed priced for phone communications and sending files (text and photos) from Lisbon (2/01/2008) to Dakar (20/01/08)
- ✓ personal phone with specific number (possibility to call and to be called),
- ✓ connexion to send files (data,sound, photos),
- ✓ coast for phone communications and file transmissions (all types of files),
- ✓ technical assistance for file transmissions

**Phone devices on internet** (ex: Skype) **are forbidden** and will automatically be blocked... These devices indeed use a lot of bandwidth and therefore have a negative effect on the connections used by the organisation and the other media present.

**Neither ASO nor TD Com will supply computers or printers.**

**All journalists or press officers are expected to provide their own equipment, which should also be insured, at their expense, by a well known solvent insurance company.**

# INSURANCE

## **THIRD PARTY LIABILITY**

### **Third Party Traffic Liability (PRESS CAR PACK)**

The organiser has taken out a third party insurance policy (AMSRé) specific to sports events using motorised land vehicles, in accordance with current legislation.

The « PRESS CAR PACK » includes this insurance premium covering notably third party traffic liability for accredited press vehicles.

Hence, in the event of an accident, a fire or an explosion during the course of the rally, the aforementioned policy insures against the financial consequences of corporal or material damage caused to third parties by the declared owners of press vehicles, this cover only being applied in addition to or in default of compulsory car insurance and within the limit of the following amounts per incident :

- 762 245,09 Euros for material damage,
- 9 146 941,03 Euros for corporal damage.

This insurance policy, governed by current legislation, under no circumstances covers the theft of vehicles, spare parts or any other personal effects. Hence, in the event of theft occurring in a country crossed by the rally, the organiser's liability may under no circumstances be invoked.

This cover will take effect when the vehicle enters into scrutineering held on the 3<sup>rd</sup> , 4<sup>th</sup> and 5<sup>th</sup> of January 2008. It will expire when the vehicle is handed over to the organiser at the port in Dakar (at the latest at midday on the 22<sup>nd</sup> of January).

This insurance only covers the official route indicated by ASO. Press vehicles which have abandoned the rally will continue to be covered by the organiser's insurance policy provided they reach Dakar or the nearest port by the most direct route.

In the event of an accident, the journalist or the press attaché or their representatives must declare this in writing at the latest within 24 (twenty-four) hours to the Press Relations Officer giving the circumstances of the accident, together with the names and addresses of any witnesses. Alternatively, an accident declaration may be sent directly to ASO's Head Office.

The insurance guarantee set forth here-above is only acquired within the terms and the limits of the insurance policy subscribed to.

### **Individual Third Party Accident Insurance**

The third party insurance policy specific to sports events using motorised land vehicles, referred to here-above, evidently does not cover Individual Third Party Liability for journalists, press officers and other accredited persons.

## **ASSISTANCE/MEDICAL REPATRIATION – MEDICAL EXPENSES**

The following assistance services are granted by the organiser to the competitors of the 2008 Dakar in case of:

- ♦ corporal damage, involving the impossibility, announced by a doctor of the rally's medical team, to carry on following the event.
- ♦ death.



## **1 – Definition**

**1.1 - Organiser:** A.S.O., has taken out a group contract with a specialist company: Mutuaide, a subsidiary of Groupama.

### **1.2 – Recipients on the 2008 Dakar rally:**

- competitors and their assistance,
- members of the organisation, their suppliers and their employees
- journalists and members of the media,
- guests of the organiser, of the partners and anyone taking part in an organised trip by V.S.O.

**1.3 - Europe :** Countries of the European Union (Germany, Austria, Belgium, Cyprus, Denmark, Spain, Estonia, Finland, France, Greece, Hungary, Ireland, Italy, Latvia, Lithuania, Luxemburg, Malta, Netherlands, Poland, Portugal, Czech Republik, United Kingdom, Slovakia, Slovenia, Sweden).

## **2 – Application**

The garanties are granted to the recipients on the course of the rally during the period of the 2008 Dakar rally (3<sup>rd</sup> to 22<sup>st</sup> of January 2008 at 12h). During this period, the competitors that have been forced to leave the race or having withdrawn from the event will carry on having a guaranty in Africa under the condition that they head to the city of Dakar or the closest harbour with departing boats to Europe, by the fastest possible way from the place of their withdrawal.

## **3 – Services**

In case of corporal damage, the rally medical team will start and organise the transportation of the recipient from the place of the accident to the rally bivouac or to the appropriate and closest medical unit, through terrestrial or/and air transport.

I will decide, based on medical facts and in respect of the adapted medical regulations:

### ***For a recipient based or living in Europe (see countries mentioned above)***

- either to place the recipient in a close-by hospital, before, if needed, organising a flight to a European facility closer to the home of the person;
- or to start and organise the transportation of the recipient to the place where he lives or to an adapted hospital close to the patients home.

### ***For a recipient based or living outside Europe***

- either to hospitalize the recipient in a close-by medical facility, before, if needed, organising a flight to a European hospital;
  - or to start and organise the transportation of the recipient to a European City, or an adapted European hospital.
- If necessary, Mutuaide Service will start searching for places in specific medical services.



The information coming from the usual doctor of the recipient, often important, can help the rally medical team to make the best possible decision.

It is however natural that the final decision in the best medical interest of the recipient, is to be taken by the Director of the rally medical team.

Added to that, in the case that the recipient refuses to follow the decision considered as the most appropriate by the Medical director, it discharges expressly Mutuaide Service and A.S.O. of any sort of responsibility, notably in case of a return trip by means other than those decided by the organisation, or in case the state of health gets worse. The recipient could no longer ask for refunding of the expenses caused.

### **3-1 – Transfer and / or repatriation of beneficiary**

If the health of the beneficiary causes, in the conditions indicated above, the rally medical team to decide to transfer them or repatriate them, the organisers assume the task of transport.

This transport may be done by all appropriate means (light medical vehicle, ambulance, scheduled flight, ambulance plane,...) if necessary under medical surveillance.

Only the medical interests of the beneficiary and the respect of current health regulations will be considered when choosing the means of transport used.

This service will never be provided to non-threatening injuries which may be treated in situ and will not stop the beneficiary from continuing the rally or from reaching Dakar by their own means.

**ATTENTION: The repatriation of a beneficiary resident or domiciled outside Europe from Europe to their country of domicile or residence is at their expense. It is therefore strongly recommended that they obtain specific insurance and check with their insurance broker the cover they are entitled to.**

### **3-2 – Medical costs (including hospital expenses) covered on the 2008 Dakar.**

For all medical costs incurred (consultation, medication prescribed by a doctor or a surgeon, medical costs decided by the medical team) the organiser will cover **1,500 Euros per beneficiary**, taxes included.

**Medical costs (including hospitalisation) incurred after repatriation to Europe remain entirely the responsibility of the beneficiary.**

**ATTENTION: Given that medical expenses over the amount of 1.500 Euros are the responsibility of the beneficiary, it is strongly recommended that participants take out specific insurance and that participants check with their insurer the guarantees they will benefit from, and that these guarantees are valid when participating in a competition.**

### **EXTENSION OF SERVICES: ADVANCE OF HOSPITALISATION COSTS**

If the beneficiary is not able to pay medical costs over 1.500 Euros, Mutuaide Service may consent to advance funds. This will be done so against a deposit cheque paid in France and made out to Mutuaide Service. In all cases the amount advanced must be repaid within 60 days of the funds being advanced.

If payment is not forthcoming, Mutuaide Service reserves the right to take all necessary action to recover funds.

### **3-3 – RAPATRIATION OF BODIES**

If a beneficiary resident or domiciled in Europe dies during the 2008 Dakar, the organisers take care of:

- the cost of transporting the body to the place where the funeral is to be held, near the place of residence.
- Expenses linked to preserving the body, imposed by current legislation,
- Expenses directly linked to the transport of the body

All other costs remain the responsibility of the family of the beneficiary.

If a beneficiary resident or domiciled outside Europe dies during the 2008 Dakar, the organisers undertake care to repatriate the body to a European airport. All other costs remain the responsibility of the family.

### **4 - Exclusions**

#### **1 – No assistance services will be provided for a bodily injury or death resulting from :**

- an intentional act on the part of the beneficiary,
- taking part in bets, brawls or fights,
- if the pathological state is not urgent,
- nervous illnesses, nervous depression, mental illness,
- the use by the beneficiary of medicines, drugs, tranquillisers and / or products taken and not prescribed medically,
- a drunken state characterised by the presence in the blood of a level of pure alcohol equal to or superior to the limit fixed by French law in vigour at the time of the accident.
- suicide or attempted suicide.

#### **2 – Are never covered**

- costs of medical equipment, prosthesis
- the costs of any type of cure
- treatment of an aesthetic nature
- costs of physiotherapy or a chiropractor
- costs of vaccines and cost of vaccination
- the costs of medical services or paramedical services or the cost of purchase of products whose therapeutic benefits are not recognised by French law.
- costs of the definitive coffin
- customs expenses.

A document detailing the range of cover described above will be issued during administrative checks.

**Participants enter the Euromilhoes – Dakar 2008 in full knowledge of the risks that the running of this rally may entail.**

### **INDIVIDUAL INSURANCE**

The repatriation of a beneficiary resident or domicile outside Europe from Europe to their country of domicile or residence is at their expense. It is therefore strongly recommended that they obtain specific insurance and check with their insurance broker the cover they are entitled to. (more information on [www.dakar.com](http://www.dakar.com))

# TARIFFS

## PRESS PLANE

Full payment of the PRESS PLANE PACK fees must be done right after you receive the confirmation of your accreditation from A.S.O. and before the 20<sup>th</sup> of November 2007.

Payment of the PRESS PLANE PACK fees must be made to VSO.

### PRESS PLANE PACK per person

Inscription press plane pack	<b>8 000 €</b>
------------------------------	----------------

#### These tariffs include

- ⇒ Access to the bivouacs
- ⇒ Meals in Africa (except in Dakar)
- ⇒ Insurance and medical repatriation
- ⇒ Accommodation in single rooms in Portugal from the 2<sup>nd</sup> of January to the 6<sup>th</sup>
- ⇒ Air transfer from Lisbon to Dakar, from 4/01/08 to 20/01/08

#### Other expenses

- ⇒ Visa expenses
- ⇒ Transmissions (telephone, Email ...)
- ⇒ Transport to Lisbon
- ⇒ Travel expenses (return plane trip from Dakar)
- ⇒ Accommodation in Dakar
- ⇒ Meals in Europe and in Dakar

## PRESS CARS « RACE COURSE » OR « ASSISTANCE COURSE »

Full payment of the PRESS CAR PACK fees must be done right after you receive the confirmation of your accreditation from A.S.O. and before the 20<sup>th</sup> of November 2007.

Payment of the PRESS CAR PACK fees must be made to ASO.

**4 people including 1 driver** will be allowed in each car providing this is stated on the car registration papers.

### PRESS CAR PACK

	N°		Unitary Tariff	Total
Car	1	X	1 600 €	1 600 €
Occupants		X	3 000 €	
Deposit	1	X	2 000 €	2 000€
<b>Total</b>				

#### These tariffs include

- ⇒ Access to the bivouacs
- ⇒ Meals in Africa (except in Dakar)
- ⇒ Insurance and medical repatriation
- ⇒ Road Books
- ⇒ Outward boat trip between Spain and Morocco for the vehicle and its occupants
- ⇒ Return boat trip from Dakar (for the vehicle)

#### Other expenses

- ⇒ Visa expenses
- ⇒ Transmissions (telephone, Email ...)
- ⇒ Travel expenses (return plane trip from Dakar)
- ⇒ Accommodation in Europe and in Dakar
- ⇒ Meals in Europe and in Dakar
- ⇒ Fuel
- ⇒ Satellite telephone (ex: Thuraya, Iridium, etc)
- ⇒ Mandatory security elements (GPS, E-track, Distress beacon)
- ⇒ Recommended security elements (Sentinel system. VHF Radio)



## **PRESS OFFICERS**

Full payment of the PRESS ATTACHE PACK fees must be done right after you receive the confirmation of your accreditation from A.S.O. and before the 20<sup>th</sup> of November 2007.

Payment of the PRESS OFFICER PACK fees must be made to VSO.

### **Press Officer Pack per person – 2<sup>nd</sup> rotation plane**

Inscription Press Officer Pack	<b>16 000 €</b>
--------------------------------	-----------------

#### **These tariffs include**

- ⇒ Access to the bivouacs
- ⇒ Meals in Africa (except in Dakar)
- ⇒ Insurance and medical repatriation
- ⇒ Accommodation in single rooms in Portugal from the 2<sup>nd</sup> of January to the 6<sup>th</sup>
- ⇒ Air transfer from Portimao to Dakar, from 7/01/08 to 20/01/08

#### **Other expenses**

- ⇒ Visa expenses
- ⇒ Transmissions (telephone, Email ...)
- ⇒ Travel expenses (return plane trip from Dakar)
- ⇒ Transport to Portimao
- ⇒ Accommodation in Dakar
- ⇒ Meals in Europe and in Dakar

# PRESS PLANE PACK

## ADMINISTRATIVE OBLIGATIONS

Each journalist benefiting from a permanent accreditation for the 2008 Dakar in the "Press pack plane", must **obligatorily be present** at scrutineering in Lisbon on the 2<sup>nd</sup>, 3<sup>rd</sup> and 4<sup>th</sup> of January 2008 and must present the valid documents referred to below in their **original form**.

In the absence of any of these original documents at administrative checks, the journalist will not be accredited for the rally. No photocopies or declarations of loss and /or theft will be accepted.

### List of original documents to be presented

- ✓ press card,
- ✓ visas,
- ✓ passport (valid until 30/06/2008),
- ✓ up to date vaccination certificates (yellow fever vaccination compulsory).
- ✓ Payment proof

## HELICOPTERS

Places will be available (according to the stages) in the organisation helicopters (Race Direction). These places are available for journalists accredited for the totality of the rally and **travelling in the press plane**. Depending on the stages, one or two places will be available daily. A pre-list will be drawn up at scrutineering in Lisbon.

## ASSISTANCE TO A COMPETITOR

A person having a press accreditation for the 2008 Dakar is not allowed to help in whatever manner a competitor of the race: transporting spare parts, giving fuel, transporting bivouac material, helping out on with mechanical problems, etc... If such is the case, this person could be expelled from the rally and involve the forced withdrawal from the race of the concerned competitor.

## TRANSPORT

The **journalists / photographers** having chosen the "Press plane pack" will be travelling from bivouac to bivouac in the press plane, from the **4<sup>th</sup> to the 20<sup>st</sup> of January 2008**, from Lisbon to Dakar.

However, ASO will not be held responsible if the security and/or organisation conditions forces them to prevent the journalists from being present on all the bivouacs.

This plane is under the responsibility of ASO and the pilots of the plane, during the whole period of the rally.

## LODGING AND CATERING



Meals in Africa are included in the "PRESS PLANE PACK" along with **accommodation in single rooms in Portugal from January 2<sup>nd</sup> to the 6<sup>th</sup>**.



## **LUGGAGE**

It is strictly forbidden to transport in one's luggage, spare parts, tools, a competitor's personal affairs ... under penalty of exclusion from the rally of the persons concerned (journalist and competitor).

**One** bag per person is authorised. This must contain the person's personal affairs and bivouac equipment (tent, sleeping bag ...) and must respect the following dimensions :

- ✓ Max. Length : 80 cm,
- ✓ Max. Width : 50 cm,
- ✓ Max. Height : 30 cm.

**The maximum authorised weight per person is 30 kg.**

# PRESS OFFICER PACK

## ADMINISTRATIVE OBLIGATIONS

Each press officer benefiting from a permanent accreditation for the 2008 Dakar in the "Press officer pack", **MUST be present** at scrutineering in Lisbon on the 2<sup>nd</sup>, 3<sup>rd</sup> and 4<sup>th</sup> of January 2008 and must present the valid documents referred to below in **their original form**.

In the absence of any of these original documents at administrative checks, the press officer will not be accredited for the rally. No photocopies or declarations of loss and /or theft will be accepted.

### List of original documents to be presented

- ✓ visas,
- ✓ passport (valid until 30/06/2008),
- ✓ up to date vaccination certificates (yellow fever vaccination compulsory).
- ✓ Payment proof

## ASSISTANCE TO A COMPETITOR

A person having a press officer accreditation for the 2008 Dakar is not allowed to help in whatever manner a competitor of the race: transporting spare parts, giving fuel, transporting bivouac material, helping out on with mechanical problems, etc... If such is the case, this person could be expelled from the rally and involve the forced withdrawal from the race of the concerned competitor.

## TRANSPORT

The **press officers** having chosen the "Press officer pack" will be travelling from bivouac to bivouac in a plane, from the **7<sup>th</sup> to the 20<sup>th</sup> of January 2008**, from Portimao to Dakar.

This plane will arrive at the bivouac at the end of the morning each day.

However, ASO will not be held responsible if the security and/or organisation conditions forces them to prevent the press officers from being present on all the bivouacs.

This plane is under the responsibility of ASO and the pilots of the plane, during the whole period of the rally.

## LODGING AND CATERING



Meals in Africa are included in the "PRESS OFFICER PACK" along with **accommodation in Portugal from January 2<sup>nd</sup> to the 6<sup>th</sup>**.

## LUGGAGE

It is strictly forbidden to transport in one's luggage, spare parts, tools, a competitor's personal affairs ... under penalty of exclusion from the rally of the persons concerned (press officer, journalist and competitor).

**One** bag per person is authorised. This must contain the person's personal affairs and bivouac equipment (tent, sleeping bag ...) and must respect the following dimensions :

- ✓ Max. Length : 80 cm,
- ✓ Max. Width : 50 cm,
- ✓ Max. Height : 30 cm.

**The maximum authorised weight per person is 30 kg.**

# PRESS CAR PACK

## ADMINISTRATIVE OBLIGATIONS

Each journalist or photographers benefiting from a permanent accreditation for the 2008 Dakar in the "Press car pack", **MUST be present** at scrutineering in Lisbon on the 2<sup>nd</sup>, 3<sup>rd</sup> and 4<sup>th</sup> of January 2008 and must present the valid documents referred to below in their **original form**.

In the absence of any of these original documents at administrative checks, the journalist / photographer will not be accredited for the rally. No photocopies or declarations of loss and /or theft will be accepted.

Depending on the type of vehicle entered, **a press car crew must be made up of a minimum of two people and a maximum of four people**. Only four-door 4x4s will be allowed to transport 4 people. No changing and/ or swapping of occupants will be authorised once the crew has been checked at scrutineering. If a member of the crew leaves his vehicle as a result of unforeseen circumstances the vehicle may continue, on condition that the organisation is informed of this. Under no circumstances may this member of the crew be replaced. **Press cards will be required for all occupants of the vehicle except for the driver.**

### List of original documents to be presented

#### For the driver:

- ✓ **proof of off-road driving.**

#### For all the occupants in the vehicle:

- ✓ press cards,
- ✓ visas,
- ✓ passports (valid until 30/07/2008),
- ✓ up to date vaccination certificates (yellow fever vaccination compulsory),
- ✓ payment proof
- ✓ national driving licence (s).

#### For the vehicle:

- ✓ valid vehicle registration certificate (no WW or W or equivalent temporary certificates for non-French countries),
- ✓ 2 detailed typewritten lists of the equipment transported in the vehicle (all transportation of spare parts or bivouac or assistance equipment for a competitor is forbidden),
- ✓ authorisation from the owner of the vehicle if he is not a member of the crew for company vehicles,
- ✓ green card insurance certificate.

## ITINERARY

The vehicles will be decorated with stickers of the rally colours during scrutineering. This will allow them to follow the rally, to access car parks, bivouacs with their vehicle and to cross frontiers.

**There will be in 2008 two categories of press cars :**

- **the ones that will follow the race course**
- **the ones that will follow only the assistance course**





### The "race course" press cars

There will be allowed to use the itinerary of their choice: race or assistance. There is no obligation to respect the stage itinerary or be present at each bivouac.

**Every day the code corresponding to the selected itinerary (race or assistance) must be entered in the GPS.**

Accredited press vehicles will form an integral part of the rally. As such, they may follow the entire rally and will have access to the following **road books**:

- ✓ « Assistance », first part distributed at scrutineering, second part at the rest day. This allows them to follow parallel routes.
- ✓ « Race », distributed daily, the night before for the following day, **at the TC finish liaison, at the entrance to each bivouac**. This allows them to follow the race route.
- ✓ If a press vehicle wishes to move ahead, « race » road books may be distributed in advance if a specific request has been made to the Head of the Press Department.

This year, l'Etrack will be used as a positioning informatical system. Every day, the press cars **MUST** allow the control of their GPS at the bivouac.

### The "assistance course" press cars

There will have to follow the assistance course only and enter every day in the GPS the assistance code.

Accredited press vehicles will form an integral part of the rally. As such, they may follow the entire rally and will have access to the following **road books**:

- ✓ « Assistance », first part distributed at scrutineering, second part at the rest day. This allows them to follow parallel routes.
- ✓ Or use Tripy (see chapter "assistance course press cars specification).

This year, a positioning system at the entrance of the bivouac will be working.

Every day, the press cars **MUST allow the control of their GPS at the bivouac**.

### CATERING

Catering in Africa (except in Dakar), water supplies as well as the first boat trip (person and vehicle) and return trip (vehicle) are included in the "Press car pack".

### DEPOSIT

For each vehicle, a deposit of 2 000 euros must be paid by cheque, made out to ASO, or by Swift bank transfer (for non-French participants), before the 15th of November 2007, to serve as a guarantee to the organiser of the respect of the following compulsory requirements :

- ✓ Obligation never to cross or drive on airport runways, never to drive or park in airport car parks, within proximity of the planes
- ✓ to inform the organisation of any abandons by all possible means,
- ✓ **to allow the check of the GPS and pay the eventual fees for fast driving**
- ✓ to comply with the customs formalities of the countries crossed,
- ✓ to comply with the present regulations,



- ✓ to return to the organiser all material or equipment supplied to the press crew on a temporary basis during the event,
- ✓ interdiction to transport equipment for a competitor or to assist a competitor (see Art. 14P4 «Forbidden Assistance » of the Car Regulations)
- ✓ to respect the safety regulations (speed in villages, at bivouacs, within limited zones, parking on race itinerary, u-turn on race itinerary)
- ✓ Obligation to pay ASO for all transmissions due
- ✓ Changing / swapping of occupants

This deposit of 2 000 euros will be returned in March 2008 to crews (all of the occupants of a same vehicle) having fulfilled the above cited requirements (non-French crews should provide their bank account details for this deposit to be returned to them by bank transfer after the rally.) **It will be returned to the person or entity having made the initial payment to ASO.**

### **COMPETITORS ASSISTANCE**

Press vehicles must offer assistance in the following circumstances: the crew of a competing vehicle is in difficulty; a competing vehicle cannot clear the track; its position constitutes a danger to the safe progress of the race. The press vehicle involved must report the incident to the organisation HQ through its satellite phone.

**Failure to respect the above clause will result in the loss of the security deposit.**

### **ELIGIBLE VEHICLES**

Petrol or diesel-engined production 4x4 off-road vehicles, conforming to Production regulations (T2), even if they have not been homologated by the F.I.A.

**At the start of the race, A.S.O. reserves the right to refuse all vehicles that are over six years old and do not appear suitable.**

Vehicles over 2,50 m in height will not be accepted at the boarding of the boat (outward and return trips)

Should a crew be forced to abandon its vehicle, it must, without fail, report the incident at the nearest Police Station and forward a copy of this declaration to ASO's Head Office in Issy-les-Moulineaux, as soon as it returns home. Repatriation of an abandoned vehicle is at the crew's expense.

### **NON RESPECT OF REGULATIONS**

Failure to respect the regulations in any way by any accredited person, will automatically lead to his exclusion from the event.

This could result in the exclusion of his crew (all of the occupants of a same vehicle) and the loss of the deposit.

### **TRAFFIC**

Just like the competitors, press cars must respect the speed limits in villages (30 or 50 km/h according to the route)

**Controls will be carried out daily on the track or at the finish at the bivouac and on certain road sections.**

All exceeding of the speed limits will be sanctioned in the following way :

- ⇒ 1<sup>st</sup> infringement : 500 euros per vehicle
- ⇒ 2<sup>nd</sup> infringement: 1 000 euros per vehicle
- ⇒ 3<sup>rd</sup> infringement : loss of accreditation and retaining of the deposit

Fees have to be paid right there or they will be taken from the caution.

U-turns are forbidden on the track.



To take photographs, you must park several metres from the track, where you will not obstruct the passage of the competitors.

**Press cars must respect the road Code and Local Regulations. Speed must be adapted to the population and to traffic : 100km/h in Morocco, 110km/h in Mauritania and 90km/h in Senegal.**

- **SENTINEL**: with a view to increasing safety when overtaking on the track, **the SENTINEL SYSTEM is strongly recommended**. It is a warning system that indicates when a vehicle is overtaking. As soon as you receive the warning signal from a competitor who is behind you (light/sound), you respond to the signal with your horn and you move to the side of the track to allow the competitor to overtake you.

### **TECHNICAL REGULATIONS FOR PRESS VEHICLES**

It is not necessary for press vehicles to be homologated by the F.I.A. However, cars must comply with all of the safety norms of the technical regulations for the Production category (T2).

These technical regulations may be consulted on the website: [www.fia.com](http://www.fia.com) (see technical regulations, annexe J )

### **SAFETY EQUIPMENT**

Beware, new elements are this year compulsory and at journalists' expense. You will find all order forms on the intranet at your disposal on the web site ([www.dakar.com](http://www.dakar.com)) as soon as ASO has confirmed your accreditation.

Each press vehicle must be presented at scrutineering with the following equipment. If any items are missing, they will not be allowed to start.

- ✓ 1 flash torch, 1 pocket torch,
- ✓ 3 hand held red smoke flares,
- ✓ 1 distress mirror, 1 compass, 1 lighter,
- ✓ 1 general map of Africa (e.g. : Michelin N° 741)
- ✓ 1 survival blanket (Metaline) per crew member,
- ✓ 1 emergency first aid kit,
- ✓ water tank of 5 litres per person
- ✓ 1 seat belt cutter per person
- ✓ **a satellite telephone with fixed antenna** (see appendix and order form on the web site)
- ✓ the **organisation GPS**. No GPS points other than those included in the road book will be provided
- ✓ **E-track** (see appendix and order form on the web site) – not mandatory for the car following the assistance course only
- ✓ 1 coded and named **distress beacon** broadcasting on the rally frequency (see appendix and order form on the web site) - not mandatory for the car following the assistance course only
- ✓ 4 points safety harness (minimum)
- ✓ approved hand operated 2 kg extinguishers
- ✓ external rear view mirrors
- ✓ 2 tow hooks (1 at the front, 1 at the rear)
- ✓ laminated windscreen
- ✓ air horn (powerful)
- ✓ individual seats
- ✓ rear lighting system complying with the Supplementary Regulations for Cars
- ✓ 2 spare wheels
- ✓ mudflaps

- ✓ 2 sandladders and 2 spades
  - ✓ a 5m towing strap
  - ✓ maximum height of cars (roof rack included) : 2,50 m.
  - ✓ fuel tank sufficient for 800 km : the spare tank(s) for petrol-engined vehicles must be of FT3 type. Diesel fuel tanks must be made and marked by an approved fuel tank manufacturer
- NB:** fuel tanks must be filled from outside the vehicle. Pipes, mountings and vents must conform to the 2006 technical regulations for off road vehicles

### "ASSISTANCE COURSE" PRESS CARS SPECIFICATION

- Etrack and the distress beacon are not mandatory
- A radio HF is recommended but not mandatory. Installation may be carried out during scrutineering in Lisbon or by appointment at TD Com. Radio equipment is intended to allow press vehicles to stay in direct contact with Race HQ/ Press HQ, other assistance vehicles, and to intervene if necessary if there is a security problem during a stage.
- Electronic road book (from the Belgian company Tripy) You have the opportunity to rent an electrical device that unrolls the road-book automatically. Only that model will be authorized. Details will be sent out later this year.

### ROLL BARS

Roll bars must correspond to F.I.A. norms : diameter, 50 mm - minimum thickness, 2 mm – Material : cold drawn seamless carbon steel – Bolts must be at least size 8 and comply with ISO 8.8 standard norms – Fasteners must be self locking or fitted with lock washers. Anchorage points and structures.

Drawing 283.5 for a crew of 3 or 4. Drawing 283.6 for a crew of 2

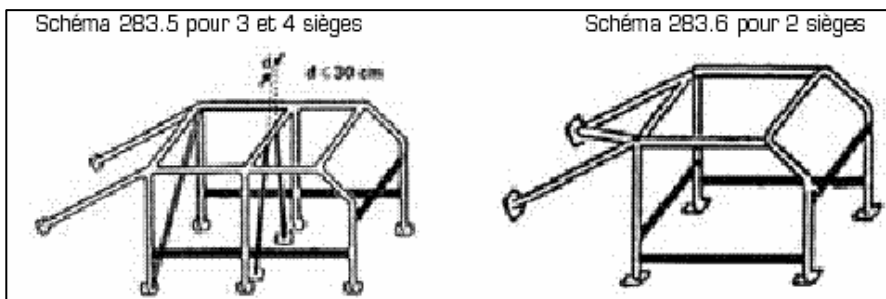

### IDENTIFICATION MARKINGS

The organisation will supply the following for all vehicles during scrutineering:

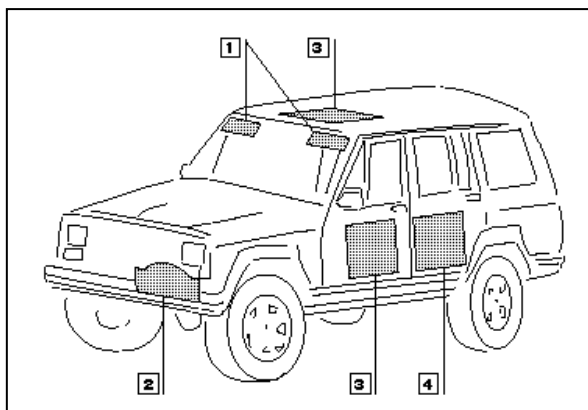

- ✓ 2 rally plates,
- ✓ 3 organisation plates carrying the car's number,
- ✓ 2 organisation advertising plates,
- ✓ 1 windscreen strip.

- ① 25 cm from windscreen stop on each side, 10 cm high, compulsory
- ② **2 rally plates measuring 43x21,5 cm at front and rear, compulsory**
- ③ 3 race plates measuring 50x52 cm, compulsory.
- ④ 2 organiser advertising plates, measuring 50x52 cm, compulsory.



## **SECURITY**

**For your own safety and that of the competitors, it is recommended to wear a helmet on the track and wearing a safety harness is compulsory.**

## **SENTINEL**

The use of the **sentinel system** (see appendix and order form on the web site) **is strongly recommended.**

## **FORBIDDEN EQUIPMENT**

The use of flashing lights is forbidden.

## **FUEL**

ASO will provide refuelling on the rally, on stages where commercial stations do not exist. Fuel supplied by the organisers on such stages must be pre-purchased from ASO. No petrol refuelling at motorcycle refuelling stops during stages will be possible for other vehicles.

Fuel must be ordered from ASO, the form will be at your disposal on the intranet made available to you.

## **TRACK CLOSURE**

Organisation "broom" vehicles will close the rally route.

In desert regions, where the route may be up to 10 km wide, it is impossible to guarantee that the sweeper vehicle will pass the exact spot where a vehicle has broken down. It is therefore up to the crew to signal their presence with their radio, satellite telephone or their on-board survival equipment.

The broom trucks will transport all occupants of broken-down vehicles, but will under no circumstances tow the vehicles in question. Recuperation of the vehicle is at the crew's expense.

Crew members who refuse to board the broom vehicle do so at their own risk, and must sign a discharge that will be presented to them by the members of the organisation in charge of closing the track.

No further recourse may be taken against the organisation as a consequence of this refusal once the discharge has been signed.



## CONTACTS

**ASO Press Department / Accreditations : Stéphanie Joyeux**  
**2, Rue Rouget de Lisle**  
**92137 Issy les Moulineaux Cedex - France**  
**Tel : +33 (0) 1.41.33.14.63 - Fax : +33 (0) 1.41.33.15.39**  
**E-mail : [sjoyeux@aso.fr](mailto:sjoyeux@aso.fr)**

**TD Com – Département Rallye Raid (Telephone + radio)**

3 Avenue des Erables  
94440 Santeny - France  
Tel : +33 (0)1 45.10.07.76  
E-mail : [rallye@tdcom.fr](mailto:rallye@tdcom.fr)  
Contact : Martine de Paiva

**Visas Express**

54 Rue de l'Ouest – BP 48  
75661 Paris Cedex 14 - France  
Tel. : +33 (0) 1.44.10.72.72 - Fax : +33 (0) 1.44.10.72.73  
E-mail : [visas-express@visas-express.fr](mailto:visas-express@visas-express.fr)

**TRIPY** (electronic de road book)

Thierry BERTE : [t.berte@tripy.be](mailto:t.berte@tripy.be)  
Tel : 0032 71 34 74 90

**ERTF Compétition (GPS)**

Parc Technologique de Soye - BP 81  
56275 Ploemeur - France  
Tel. : +33 (0) 2.97.87.25.85 - Fax : +33 (0) 2.97.37.59.21  
E-mail : [competition@ertf.com](mailto:competition@ertf.com)  
Contact : Cathy Tournaire

**PROTECH ENGINEERING (Sentinel)**

6 bis, avenue de la Gare  
34 570 Pignan  
Tel. : +33 (0)4.67.27.35.84 - Fax : +33 (0)4.67.50.95.64  
E-mail : [contact@sentinel.name](mailto:contact@sentinel.name)  
Contact : Anne LAJARA

**Accomodation / VSO**

(in Europe and in Dakar – Return flight from Dakar)

- ✓ Jean-Marc Théodose
- ✓ Sophie Seroussi

2 Rue Rouget de Lisle - 92137 Issy Les Moulineaux Cedex  
Tel : +33 (0) 1.41.33.14.85 - Fax : +33 (0) 1.41.33.14.86  
E-mail : [vso@aso.fr](mailto:vso@aso.fr)



# INDIVIDUAL ATTESTATION

I, the undersigned ..... accredited by ASO on the Dakar 2008 declare that I have read the Press regulations and I promise to accept and respect them.

Signed in : ..... Date : .....

Signature preceded by the comment "read and approved"

Media or team stamp